

Blank Stock Lubrication

The Uni-Roller® S2 Powered is the ultimate solution for blank stock lubrication. Combined with a SmartFlow™ or SPR-2000 JR™ programmable fluid controller, the Uni-Roller® S2 Powered will apply the correct amount of fluid for your application and do it consistently from one blank to the next.

- Reduce lubricant consumption by 50% or more
- Quick-change rollers for easy maintenance
- Cleaner floors & work area

The internally-supplied rollers are essential to precisely applying the fluid. Inside each of the rollers is a dispenser tube with small holes placed along its length. Fluid is injected into the dispenser tubes from the fluid controller and dispensed across the inside of the rollers.

The lubricant is transferred to the stock through durable polyester felt or polyurethane foam roller covers. These cover materials apply the lubricant smoothly and evenly across both the top and bottom of the stock.

The Uni-Roller® S2 Powered applies the exact amount of lubricant required. This eliminates the mess and waste associated with in-die spray systems and externally lubricated roller systems. The result is not only a cleaner shop, but also significant savings from decreased fluid waste, improved die life, better part quality and increased machine up-time. Many customers have reported savings resulting in a return on investment of less than six months!

The brushed stainless steel guards protect the rollers and guide material when loading coil stock or feeding blanks. With the guards removed for better access, a roller can be changed in about a minute using a single wrench. The Uni-Roller® S2 Powered lubricator is built to handle any manufacturing environment without sacrificing ease of maintenance.



The Uni-Roller® S2 Powered lubricator uses a photo eye sensor to detect blanks and provides an input to the SmartFlow™ programmable fluid controller.

A single roller set is used for widths of 18" [457 mm] or less where the lower roller is directly driven. For blanks over 18" [457 mm] wide, multiple 12" [305 mm] wide roller sets are staggered and overlapped. Each lower roller is driven by a heavy-duty chain from a central shaft.

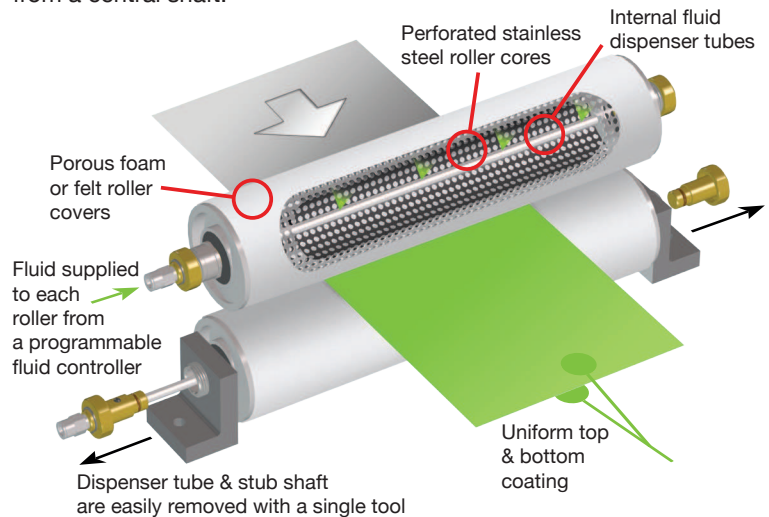

Single roller entry side

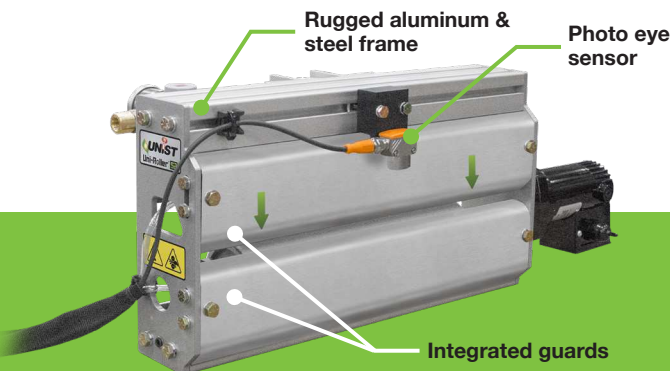

Single roller exit side

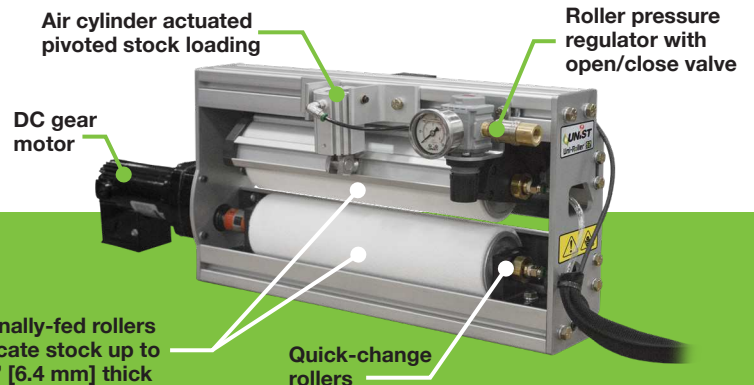

Single roller unit shown above. Lubricators with multiple DC roller sets have guards on both entry and exit sides.

Standard Sizes

Single roller coverage of 6" [152 mm] to 18" [457 mm]



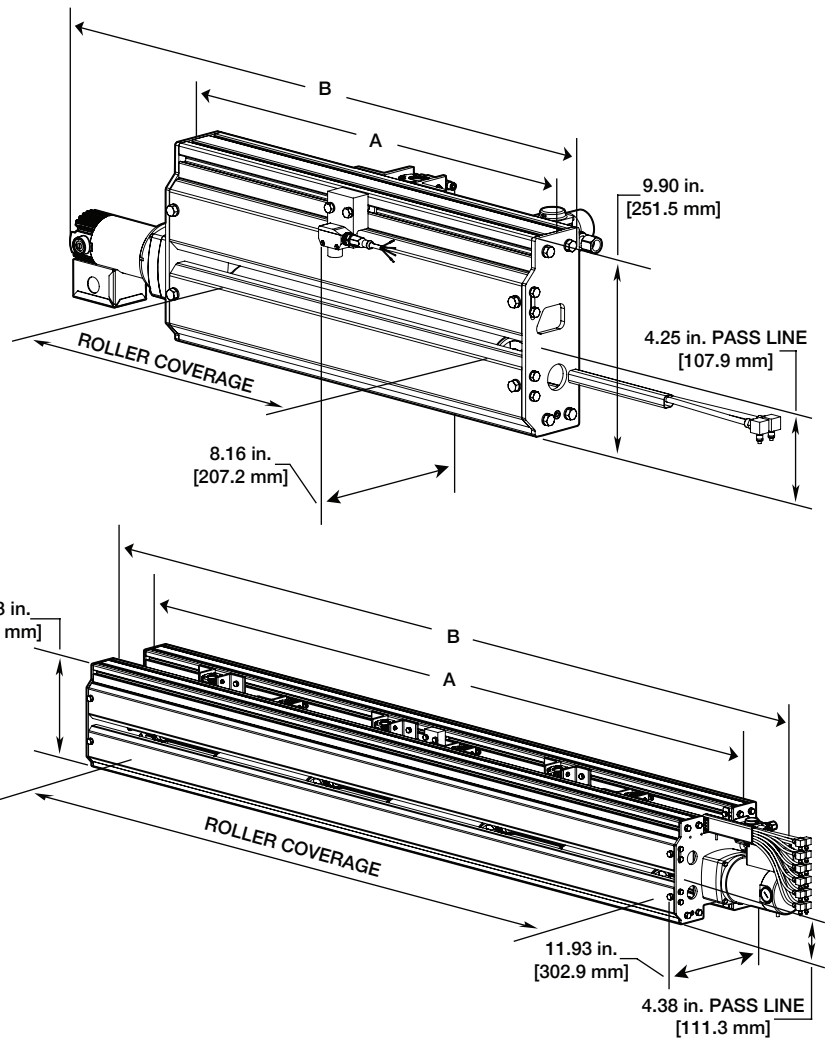

Roller coverage	A (extrusion length)	B (overall width)
6" [152 mm]	12.00" [304.8 mm]	20.24" [514.1 mm]
12" [305 mm]	18.00" [457.2 mm]	26.24" [666.5 mm]
18" [457 mm]	24.00" [609.6 mm]	32.24" [818.9 mm]

Multiple rollers coverage over 18" [457 mm]

Roller coverage	A (extrusion length)	B (overall width)
23.5" [597 mm]	30.00" [762.0 mm]	41.18" [1046.0 mm]
35" [889 mm]	42.00" [1066.8 mm]	53.18" [1350.8 mm]
46.5" [1181 mm]	54.00" [1371.6 mm]	65.18" [1655.6 mm]
58" [1473 mm]	66.00" [1676.4 mm]	77.18" [1960.4 mm]
69.5" [1765 mm]	78.00" [1981.2 mm]	89.18" [2265.2 mm]



Features & Options

Standard features	Options
 <p>Polyester felt cover Extremely durable and compatible with a broad range of fluids.</p>	 <p>Polyurethane foam cover Reduces uneven wear on cover when a variety of stock widths and thicknesses are used. Due to limited fluid compatibility, consult Unist.</p>
<p>Standard fluid dispenser tube Best choice for most applications with the widest range of fluid compatibility and flow rates.</p>	<p>Low volume fluid dispenser tube For use in applications requiring coverage of 50 mg/ ft² [538 mg/m²] or less.</p>
 <p>Variable speed DC drive Manual speed control through a potentiometer for speeds up to 145 ft/min [44 m/min].</p>	 <p>AC variable frequency drive Automated speed control for speeds up to 150 ft/min [46 m/min]. Not available on single roller units.</p>



MONTFORT INTERNATIONAL Ltd

2500 avenue Watt, Québec (QUÉBEC) Canada G1P 3T3
+ 1 (418) 877-0778 - (800) 463-6668 - info@montfort-international.com